

Miss MORAVA

TOWING MACHINE

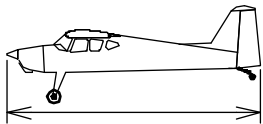

Order N°: 02046



1960 mm



2420 mm

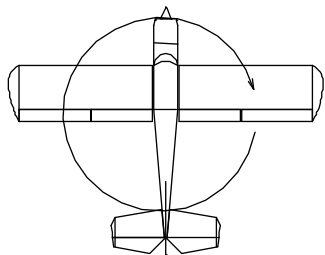

99,5dm²
75,4-85,4 g/dm²



7,5 - 8,5 kg

Radio system you'll need :

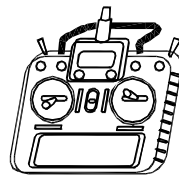

- ailerons - 2 servos
- flaps - 2 servos
- elevator - 2 servos
- rudder
- motor
- tow hook

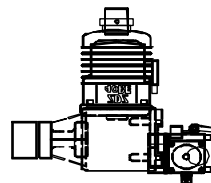

30 - 55 ccm



NACA 2415

Není-li uvedeno jinak, všechny
neoznačené míry jsou v milimetrech
UNLESS STATED OTHERWISE, ALL
DIMENSIONS ARE IN MILLIMETERS

Manufactured by:
TOPMODEL CZ
679 05 HABRŮVKA 100 - CZECH REPUBLIC
www.topmodelcz.com
e-mail: info@topmodelcz.cz

Part No.	Part name	Material, dimensions	Loose	In bag
	building plan	A1	01	-
1	fuselage	balsa- plywood assembly	01	-
1-2	elevator & rudder servo tray	plastic 3 x 62 x 80 mm	-	03
1-21	servo tray screw	wood screw 2,9 x 9,5 mm		12
1-22	servo holder	polyurethan 20 mm	-	06
1-23	servo strap	fiberglass 1,5x14x64 mm + screw M3x25 mm	-	03 + 06
1-3	tank holder	plywood 3x100x180 mm	-	01
1-4	RX holder	plywood 3x55x112 mm	-	01
1-5	fuselage cover	plastic 3x172x200 mm	-	01
1-51	fuselage cover fixing	fiberglass ϕ 4x30, hatch latch	-	03 + 02
2	wing	balsa assembly	02	-
24	wing joiner	alu tube ϕ 35 mm, l = 720 mm	01	-
2-1	aileron	balsa assembly	02	-
2-11	flap	balsa assembly	02	-
2-21	centering pin	alu tube ϕ 12 mm, l = 330 mm	-	01
2-3	hook	ϕ 3 mm	-	02
2-4	ailerons & flaps servo tray	plastic 3 x 62 x 80 mm	-	04
2-41	servo tray screw	wood screw 2,9 x 9,5 mm	-	16
2-42	servo holder	polyurethan 20 mm	-	08
2-43	servo strap	fiberglass 1,5x14x64 mm+ screw M3x25 mm	-	04 + 08
2-5	aileron & flap pushrod	threaded rod M3, length 48 mm, carbon tube ϕ 5/3 L=25 mm	-	04 + 04
2-6	clevis	metal M3 + nut M3	-	08 + 08
2-8	aileron horn	fiberglass plate 2 mm	-	02
2-81	flap horn	fiberglass plate 2 mm	-	02
2-82	flap hinge	fiberglass plate 1,5 mm	-	12
2-83	flap hinge	fiberglass plate 2 mm	-	04
2-84	shaft hinge	MPJ 4820	-	06
2-85	backlash washer	fiberglass plate 1 mm	-	12
3	horizontal stabilizer	balsa assembly	02	-
3-3	elevator joiner	alu tube ϕ 12/10 mm, length 290 mm	-	01
3-31	centering pin	fiberglass ϕ 5 mm x 30 mm	-	02
3-4	elevator fixing	screw M3 x 12 mm	-	02
3-5	elevator pushrod	threaded rod M3, L=155 + 180 mm, carbon tube ϕ 5/3 L=138+157 mm	-	01+01+01+01
3-6	clevis	metal M3 + nut M3+ball link M3		02+02+02
3-8	elevator horn	fiberglass plate 2 mm	-	02
4	vertical tail	balsa assembly	01	-
4-5	rudder pushrod	threaded rod M3, length 67 mm, carbon tube ϕ 5/3 L=43 mm	-	01+01
4-6	clevis	metal M3 + nut M3	-	02+02
4-8	rudder horn	fiberglass plate 2 mm	-	01
6	canopy	plastic 1 mm	03	-
6-1	canopy fixing	screw ϕ 2,2x6,5 mm	-	25
7	stickers	sets	01	-
8-2	wheel axle	MPJ 2872	-	02
8-3	wheel fixing	wheel collar	-	02
9	engine cowl	fiberglass	01	-
9-0	engine cowl fixing	wood screw 2,9 x 9,5 mm	-	05
9-21	throttle linkage	fiberglass ϕ 2 mm, length 330 mm	01	-
9-22	clevis	metal M2 + MPJ 2012	-	02+02
10	main landing gear	aluminium 5 mm	01	-
10-1	landing gear fixing	screw M5 x 20 mm + nut M5 + washer	-	03 + 03 + 06
10-3	tailwheel	with shock absorber, steerable, wheel ϕ 35 mm	-	01
10-31	tailwheel steering horn	Fiberglass 2 mm, screw ϕ 2,9x18 mm		01+02
11	hinge	Plastic 25 x 35 mm	-	15

Položka	Název dílu	Materiál, rozměr	Volně / ks	Balíček/ ks
	montážní návod		01	-
1	trup	balsa konstrukční	01	-
1-2	držák serv SOP + VOP	plast 3 x 62 x 80 mm	-	03
1-21	upevnění držáku	vrut ϕ 2,9 x 6,5 mm	-	12
1-22	aretače serva	polyuretan 20mm	-	06
1-23	upevnění serva	sklotextit 1,5x14x64 mm + šroub M3x25 mm	-	03+06
1-3	deska nádrže	Př. 3x100x180 mm	-	01
1-4	držák přijímače	Př. 3x55x112 mm	-	01
1-5	kryt trupu	plast 3x172x200 mm	-	01
1-51	upevnění krytu	laminát ϕ 4x30 mm, zámeček	-	03+02
2	křídlo	balsa konstrukční	02	-
24	spojka křídla	dural ϕ 35mm L = 720mm	-	01
2-1	křídélko	balsa konstrukční	02	-
2-11	vztlaková klapka	balsa konstrukční	02	-
2-21	aretační trubka	dural ϕ 12 mm L = 330 mm	-	01
2-3	zajištění křídla	háček ϕ 3mm	-	02
2-4	držák serv křídélka a klapky	plast 3 x 62 x 80 mm	-	04
2-41	upevnění držáku	vrut ϕ 2,9 x 6,5 mm	-	16
2-42	aretače serva	polyuretan 20mm	-	08
2-43	upevnění serva	sklotextit 1,5x14x64 mm+ šroub M3x25 mm	-	04+08
2-5	táhlo křídélka a klapky	M3 L = 48mm, uhlík ϕ 5/3 L=25 mm	-	04+04
2-6	koncovka táhla	Kovová vidlička M3, matice M3	-	08+08
2-8	páka křídélka	sklotextit 2 mm	-	02
2-81	páka klapky	sklotextit 2 mm	-	02
2-82	závěs klapky	sklotextit 1,5mm	-	12
2-83	závěs klapky	sklotextit 2mm	-	04
2-84	čep závěsu	MPJ 4820	-	06
2-85	distanční podložka	sklotextit 1mm	-	12
3	výškovka	balsa konstrukční	02	-
3-3	spojka výškovky	dural ϕ 12mm l=290 mm	-	01
3-31	aretační kolík	laminát ϕ 5x 30mm	-	02
3-4	zajištění výškovky	šroub m3x12mm	-	02
3-5	táhlo výškovky	M3 L = 155+ 180 mm, uhlík ϕ 5/3 L=138 + 157mm	-	01+01+01+01
3-6	koncovka táhla	vidlička kovová M3, matice M3, MPJ 2450	-	02+02+02
3-8	páka VOP	sklotextit 2 mm	-	02
4	směrovka	balsa konstrukční	01	-
4-5	táhlo směrovky	M3 L = 67mm, uhlík ϕ 5/3 L = 43mm	-	01+01
4-6	koncovka táhla	vidlička kovová M3, matice M3	-	02+02
4-8	páka SOP	sklotextit 2 mm	-	01
6	kabina	folie 1mm	03	-
6-1	upevnění kabiny	vrut ϕ 2,2x6,5 mm	-	25
7	obtisky	sada	05	-
8-2	hřídel kola	MPJ 2872	-	02
8-3	zajištění kola	stavěcí kroužek	-	02
9	motorový kryt	laminát	01	-
9-0	uchycení krytu	vrut ϕ 2,9 x 9,5 mm	-	05
9-21	táhlo motoru	laminát ϕ 2 L= 330 mm	-	01
9-22	koncovka táhla	vidlička kov. M2, MPJ 2012	-	02+02
10	podvozek	dural 5 mm	01	-
10-1	uchycení podvozku	šroub M5x20 mm, matice, podložka	-	03+03+06
10-3	ostruha	komplet s kolem ϕ 35mm	-	01
10-31	páka ovládání ostruhy	sklotextit 2mm, vrut ϕ 2,9x18 mm	-	01+01
11	závěsy	plast 25 x 35 mm	-	15

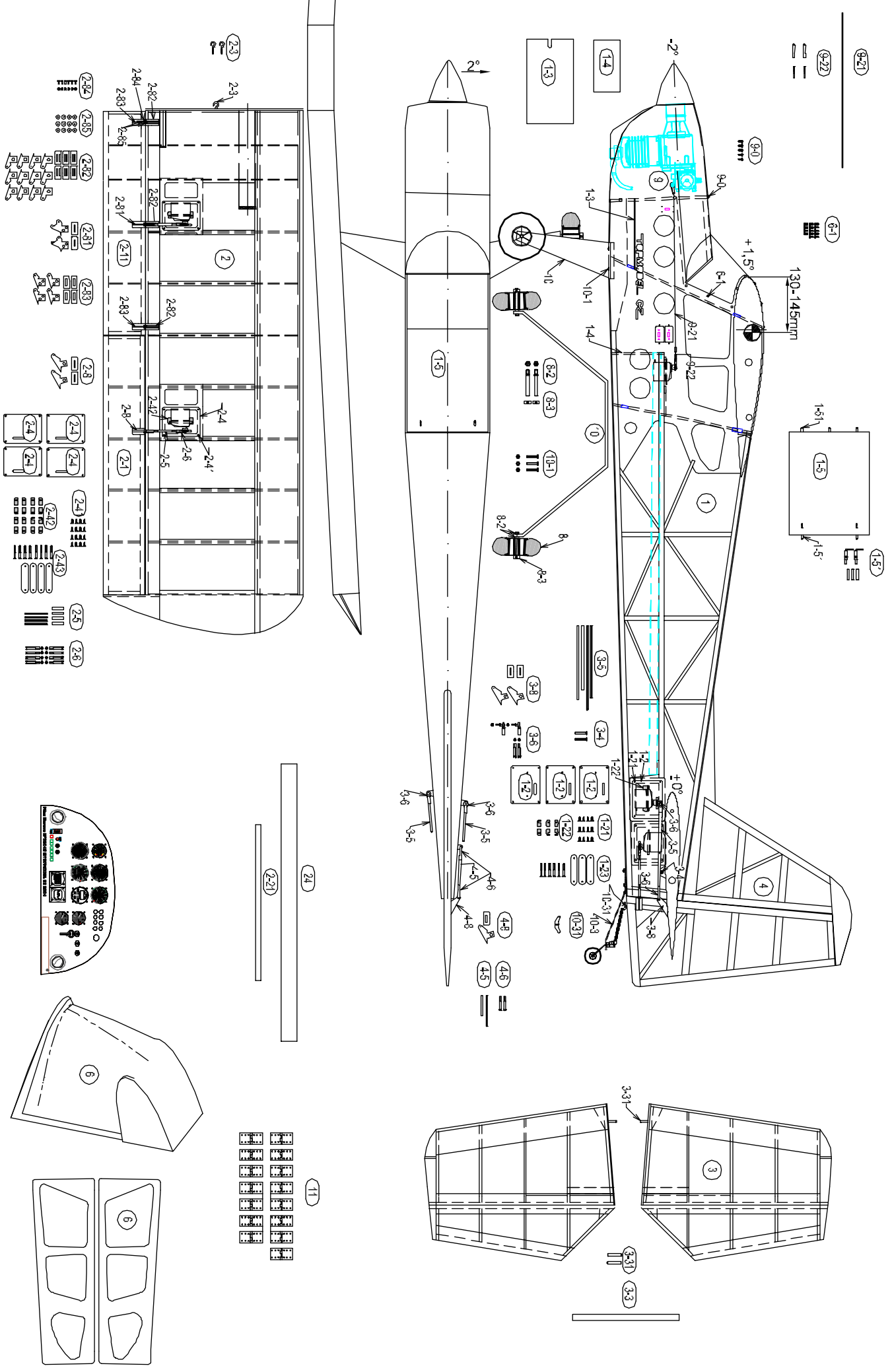

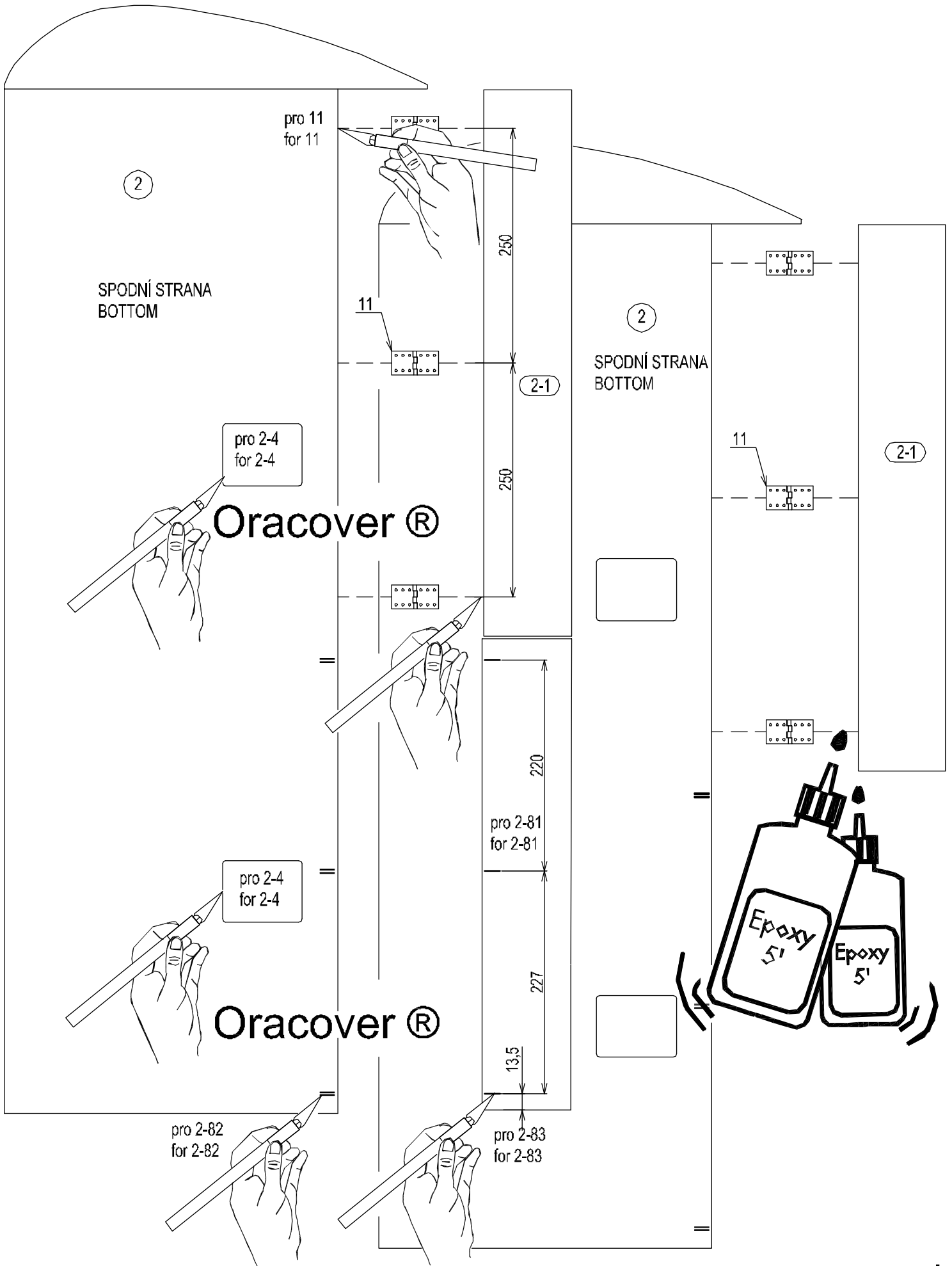

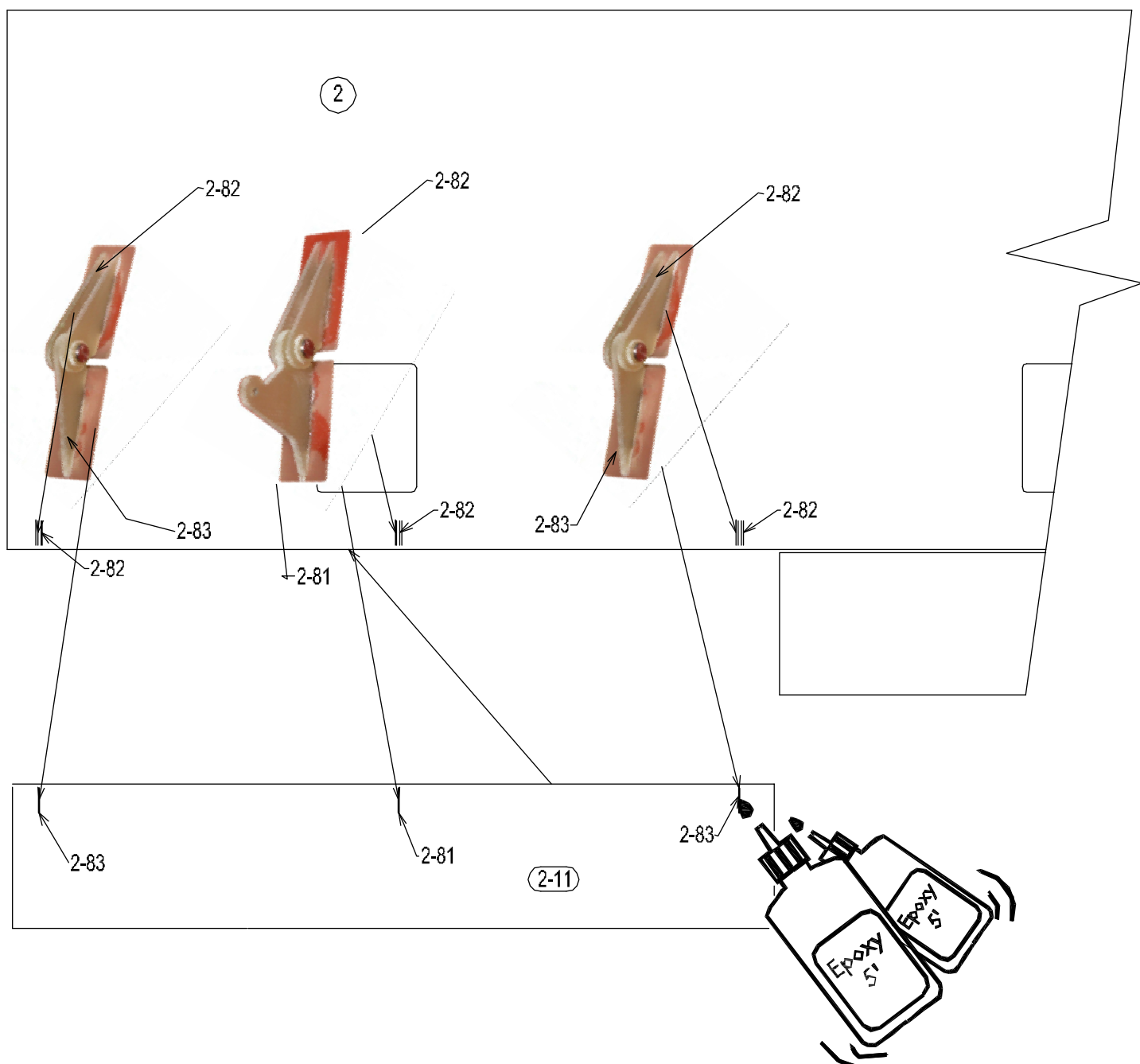
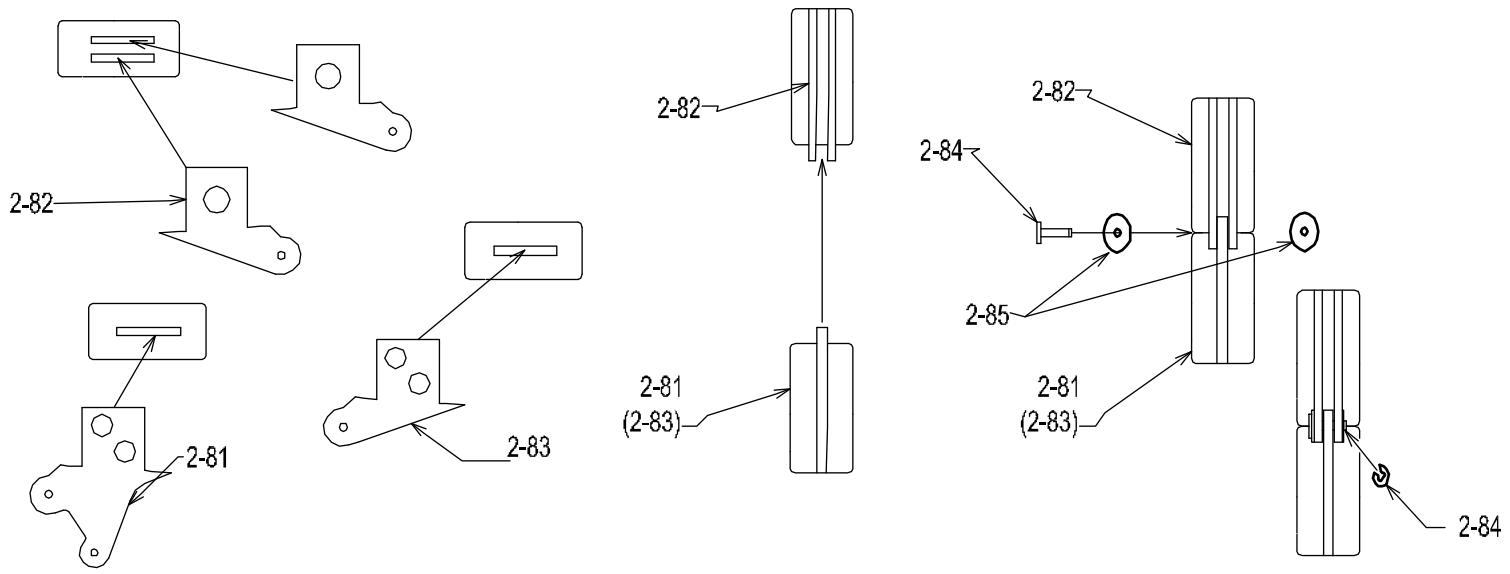

Pozn.: zobrazena je levá montáž serva

Note: there is assembly of left servo on the picture

pro servo: křídélek, klapek, VOP, SOP
- 4x levá + 3x pravá montáž
for servos: ailerons, flaps, elevator,
rudder - 4x left + 3x right

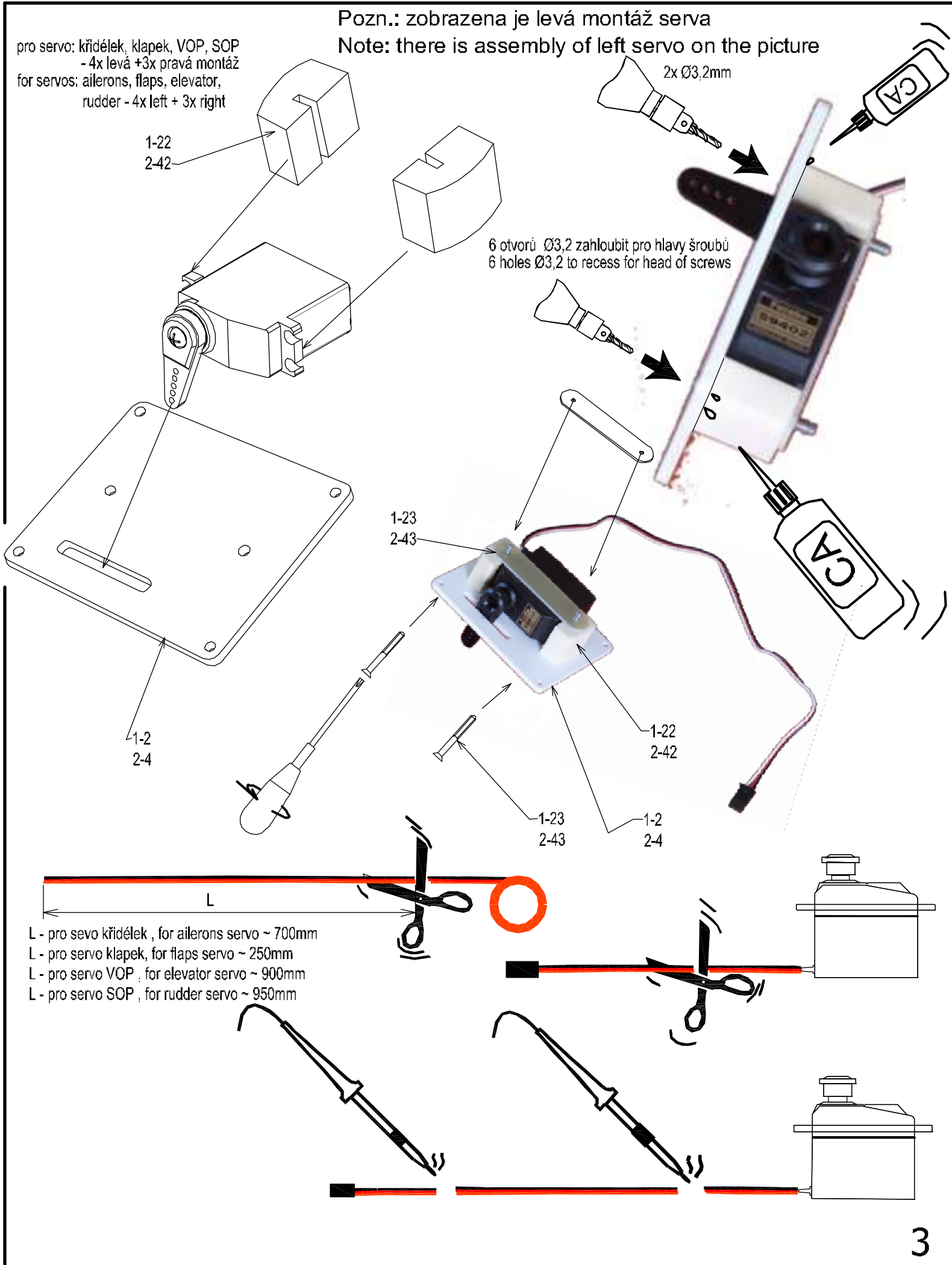

6 otvorů Ø3,2 zhloubit pro hlavy šroubů
6 holes Ø3,2 to recess for head of screws

2x Ø3,2mm

1-23
2-43

1-2
2-4

1-22
2-42

1-23
2-43

1-2
2-4

- L - pro servo křídélek , for ailerons servo ~ 700mm
- L - pro servo klapek, for flaps servo ~ 250mm
- L - pro servo VOP , for elevator servo ~ 900mm
- L - pro servo SOP , for rudder servo ~ 950mm

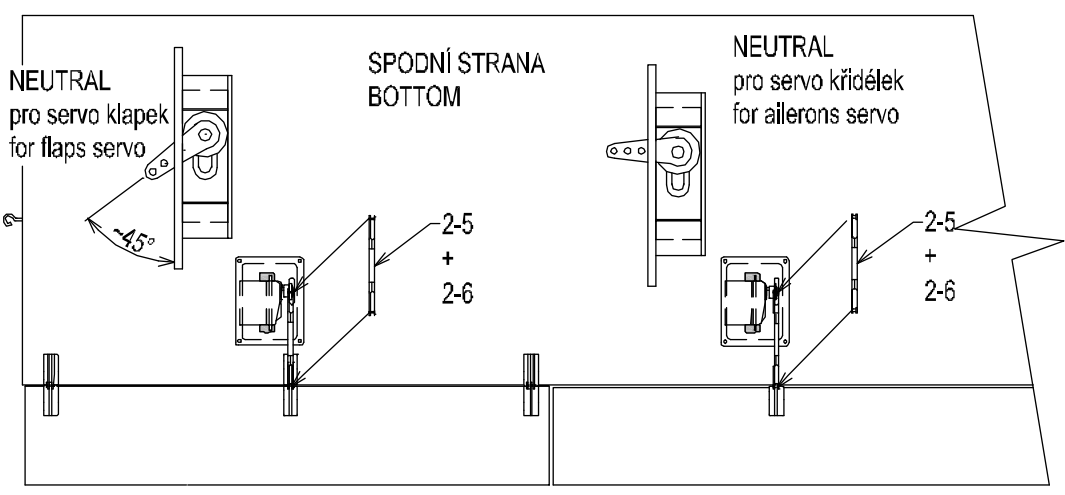
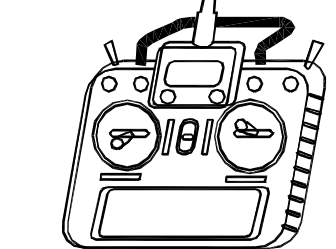
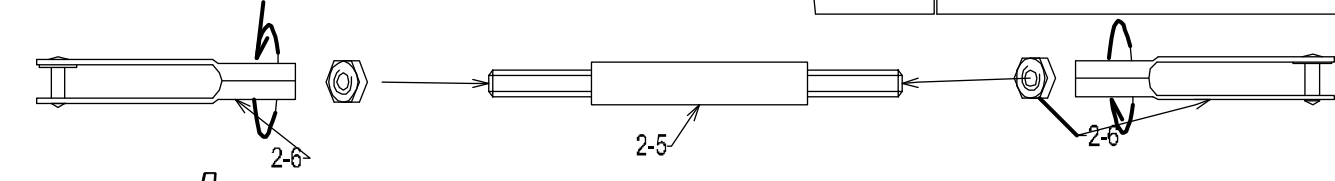
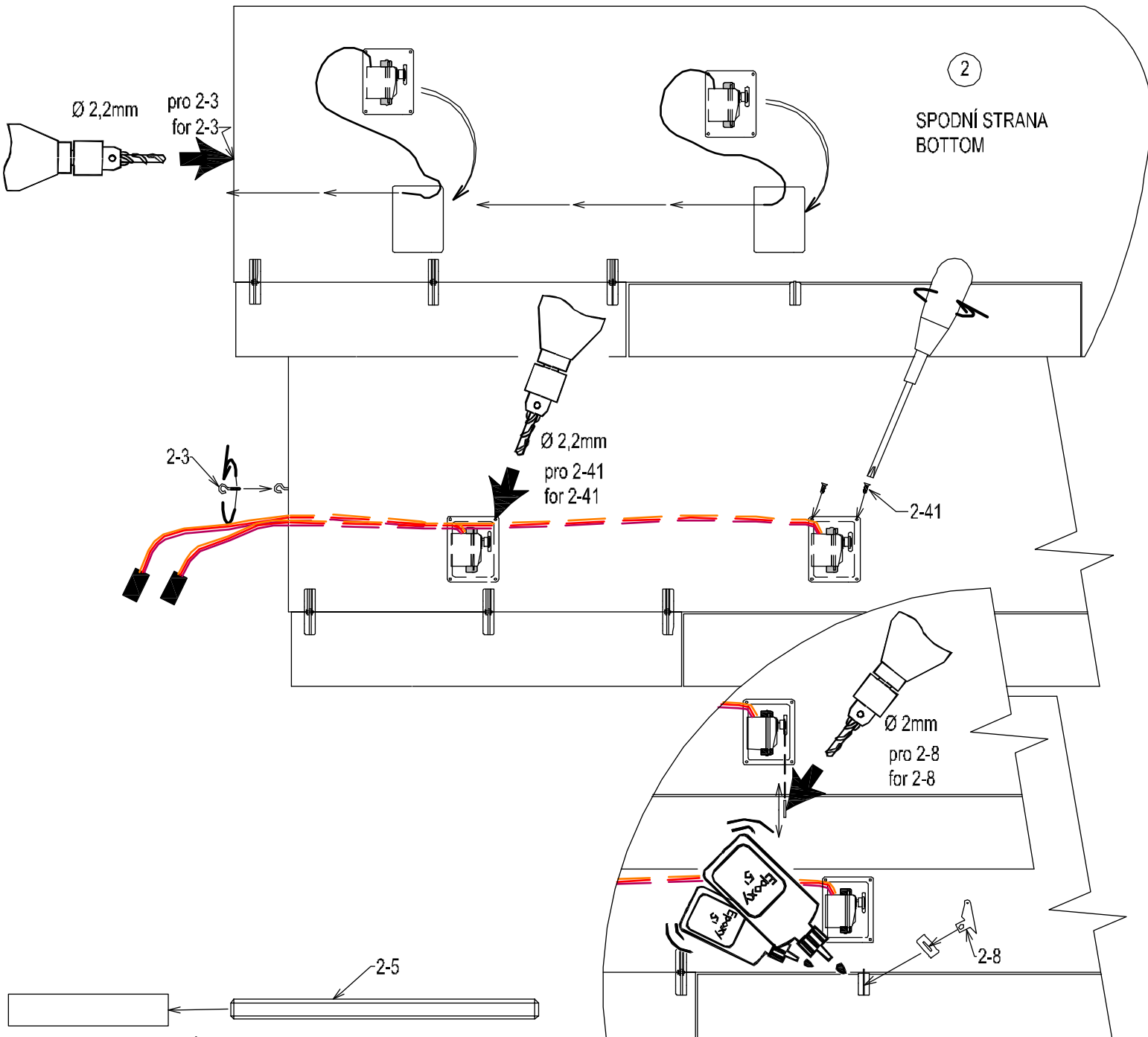

Oracover®

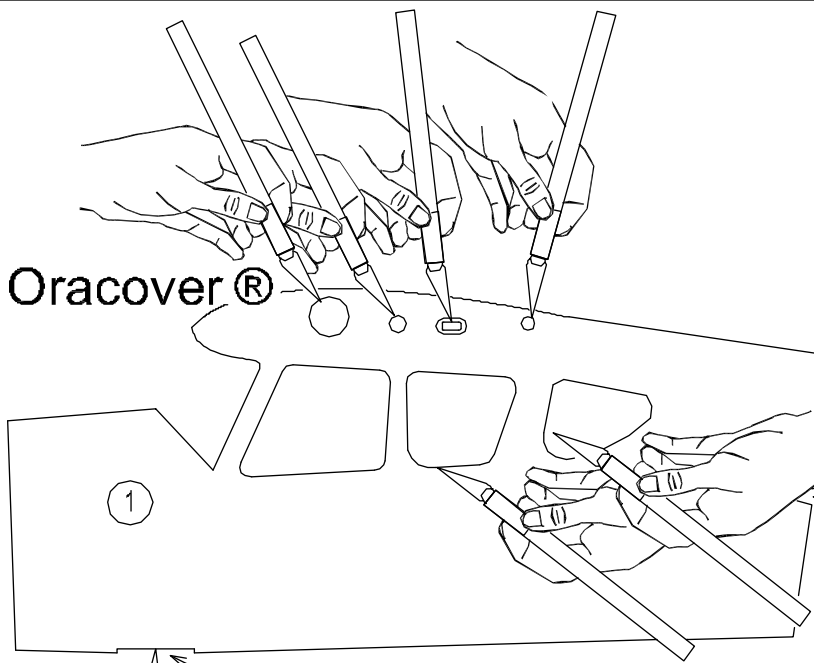

Oracover®

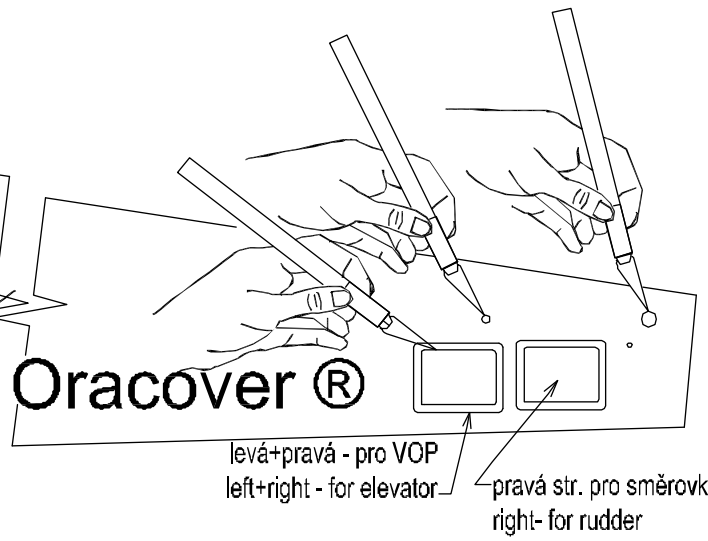

levá+pravá - pro VOP
left+right - for elevator

pravá str. pro směrovku
right- for rudder

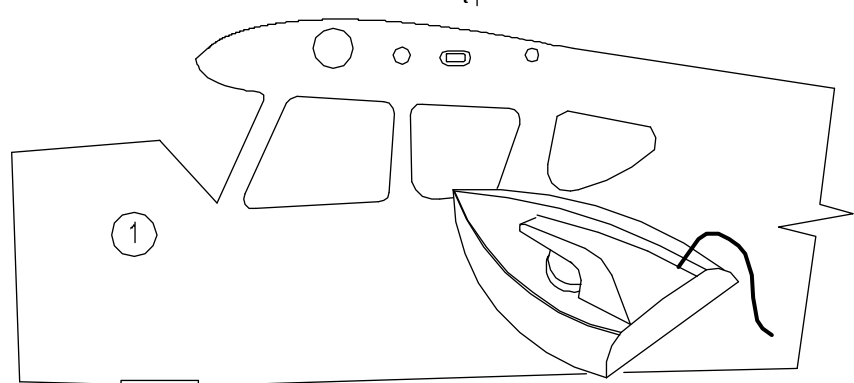
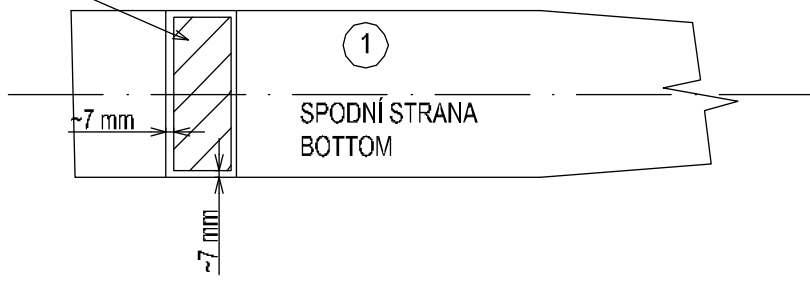
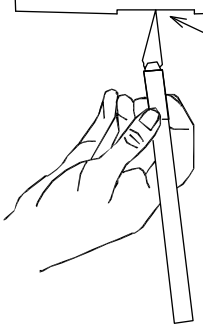

Oracover®

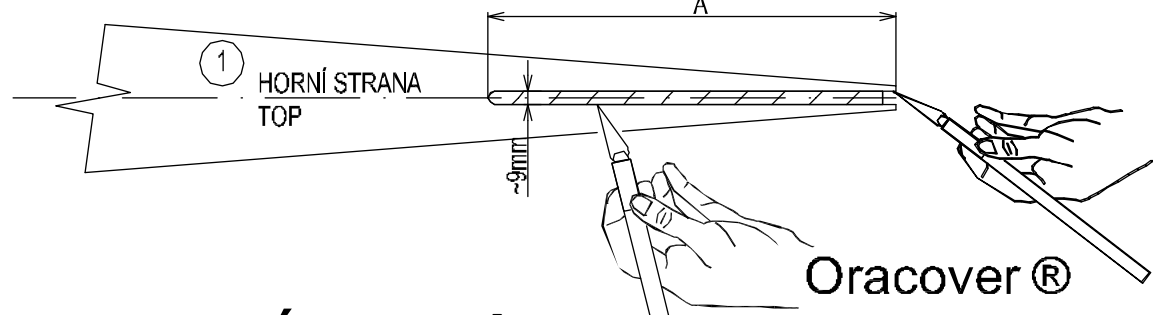
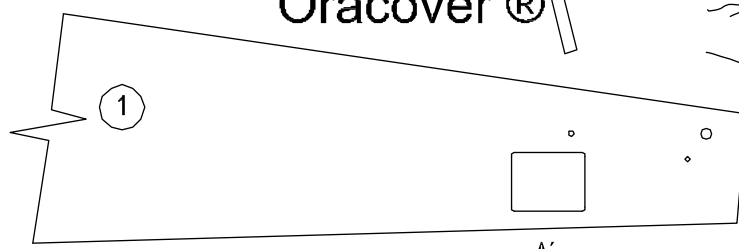
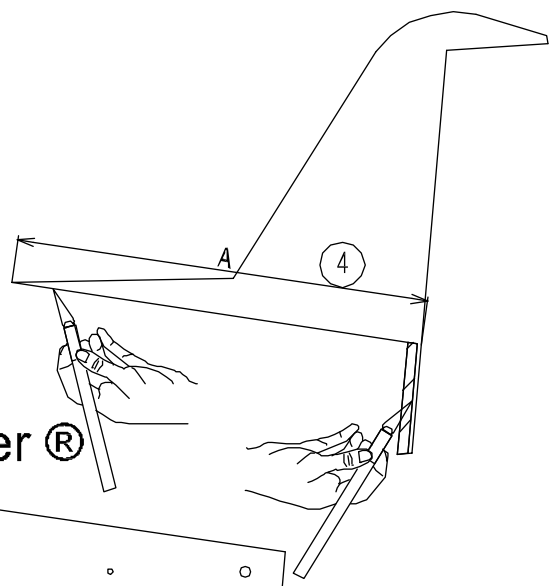

Oracover®

$$A' = A - 3\text{mm}$$

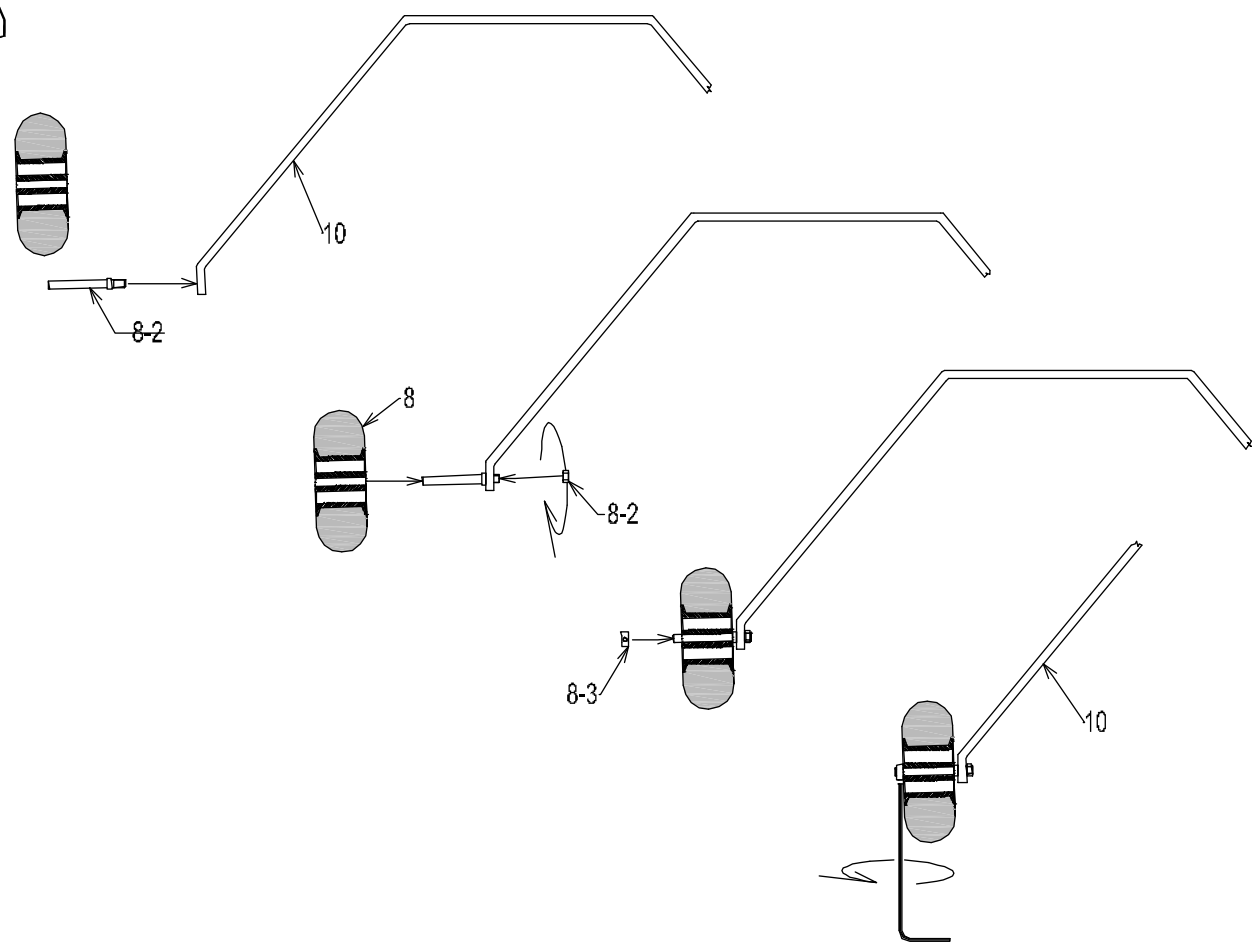
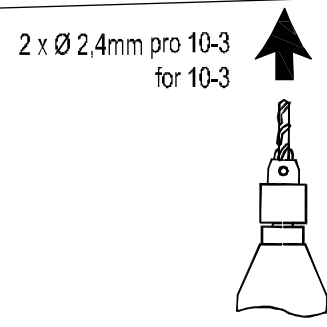
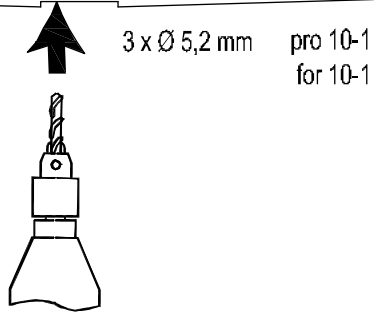
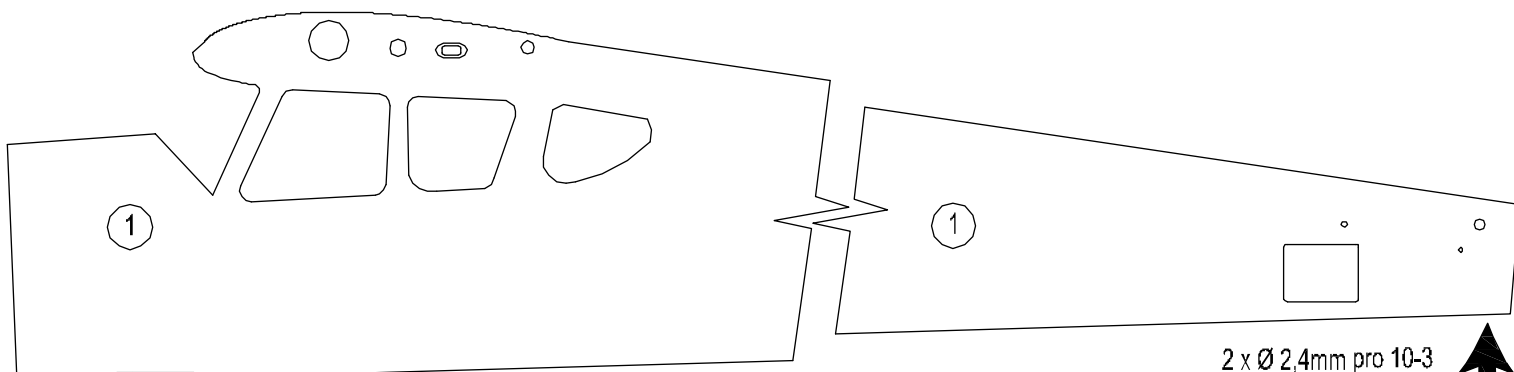
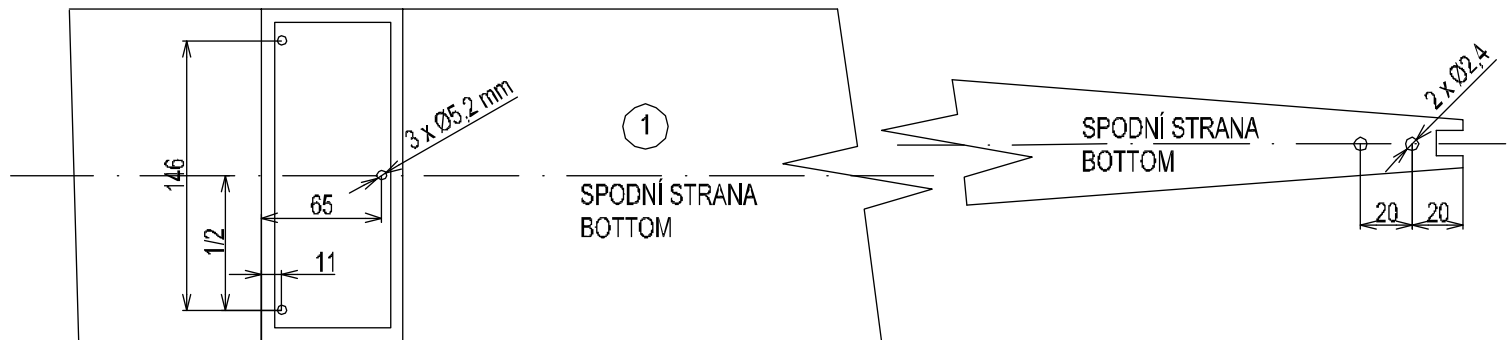

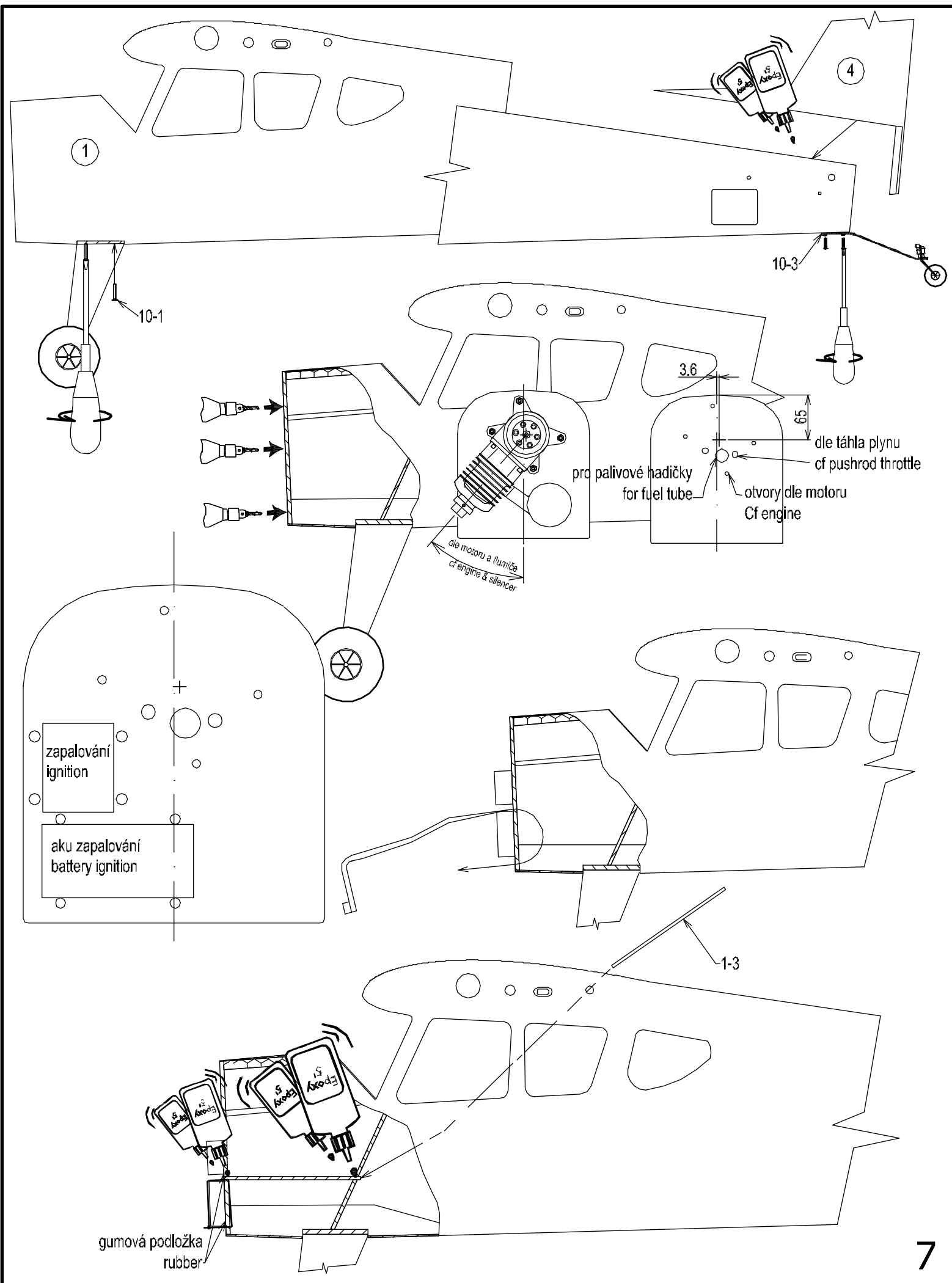

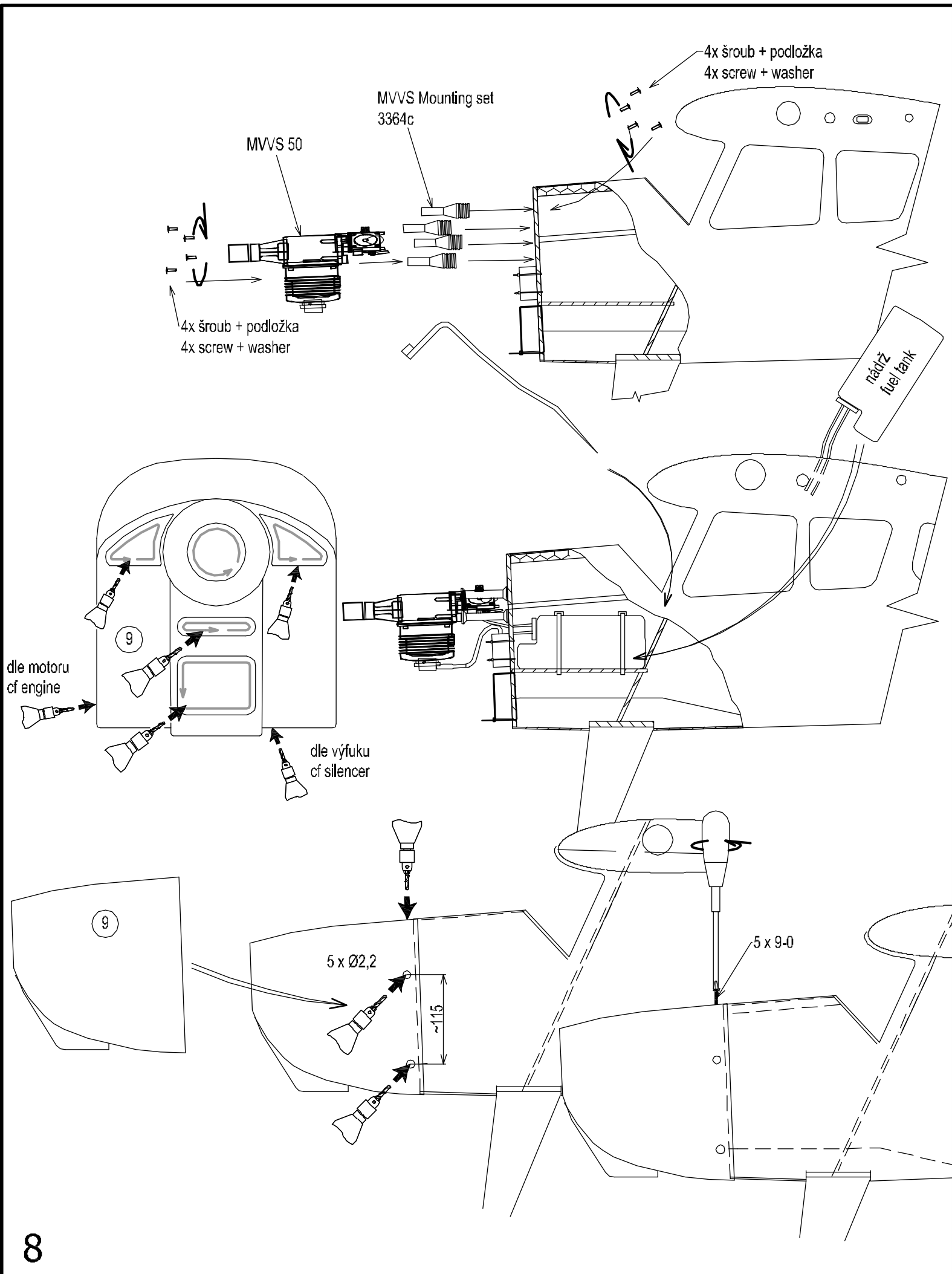

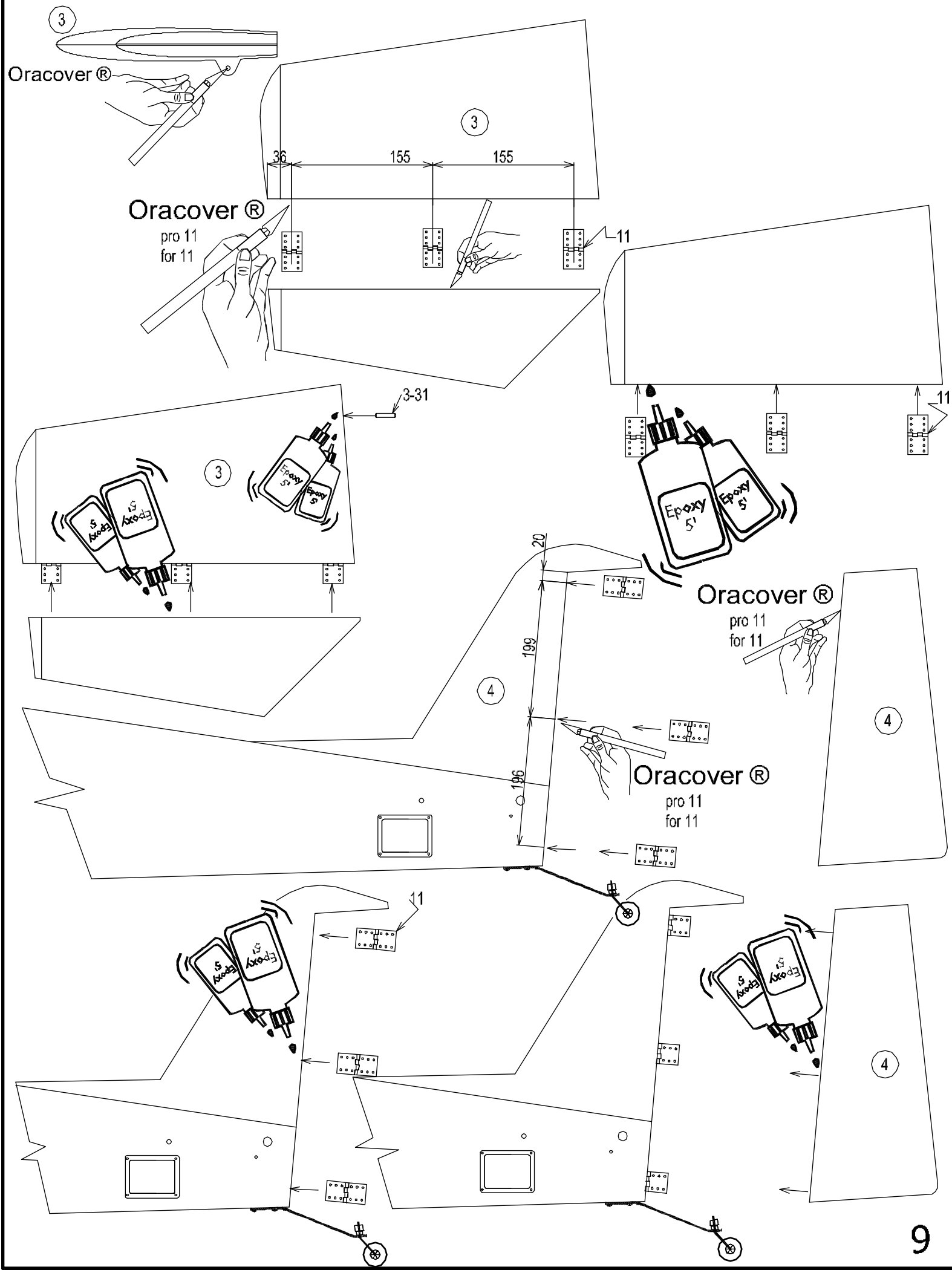

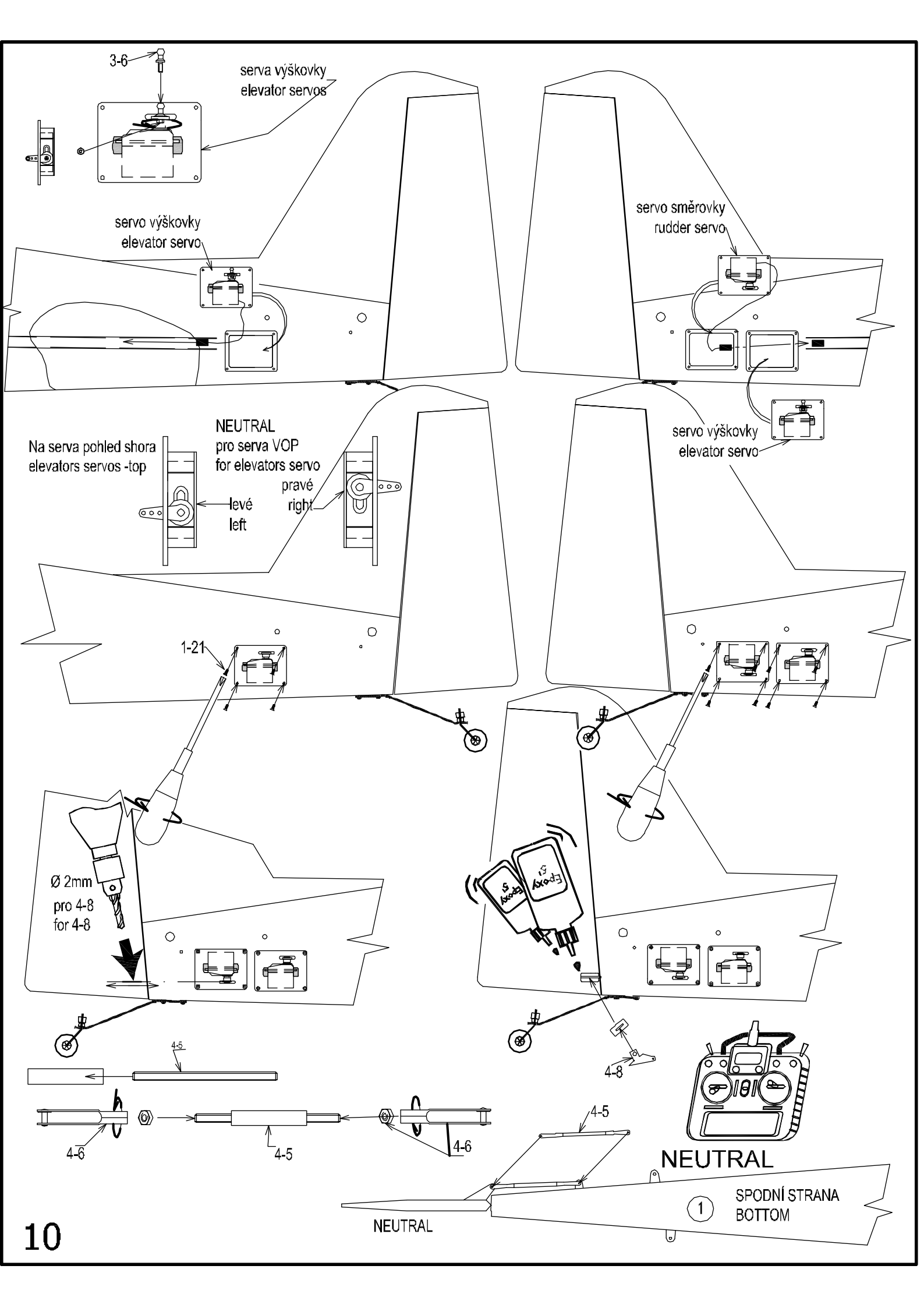

3-6

serva výškovky
elevator servos

servo výškovky
elevator servo

servo směřovky
rudder servo

servo výškovky
elevator servo

Na serva pohled shora
elevators servos -top

NEUTRAL
pro serva VOP
for elevators servo

levé
left

pravé
right

1-21

Ø 2mm
pro 4-8
for 4-8

NEUTRAL

1

SPODNÍ STRANA
BOTTOM

NEUTRAL

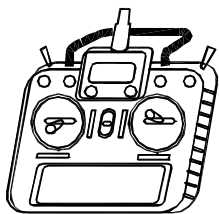
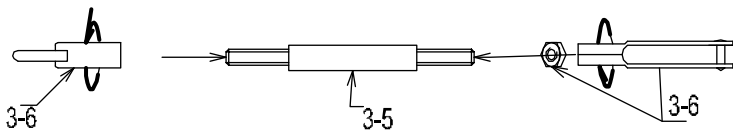
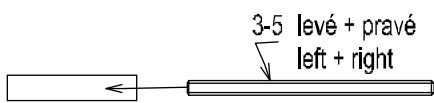
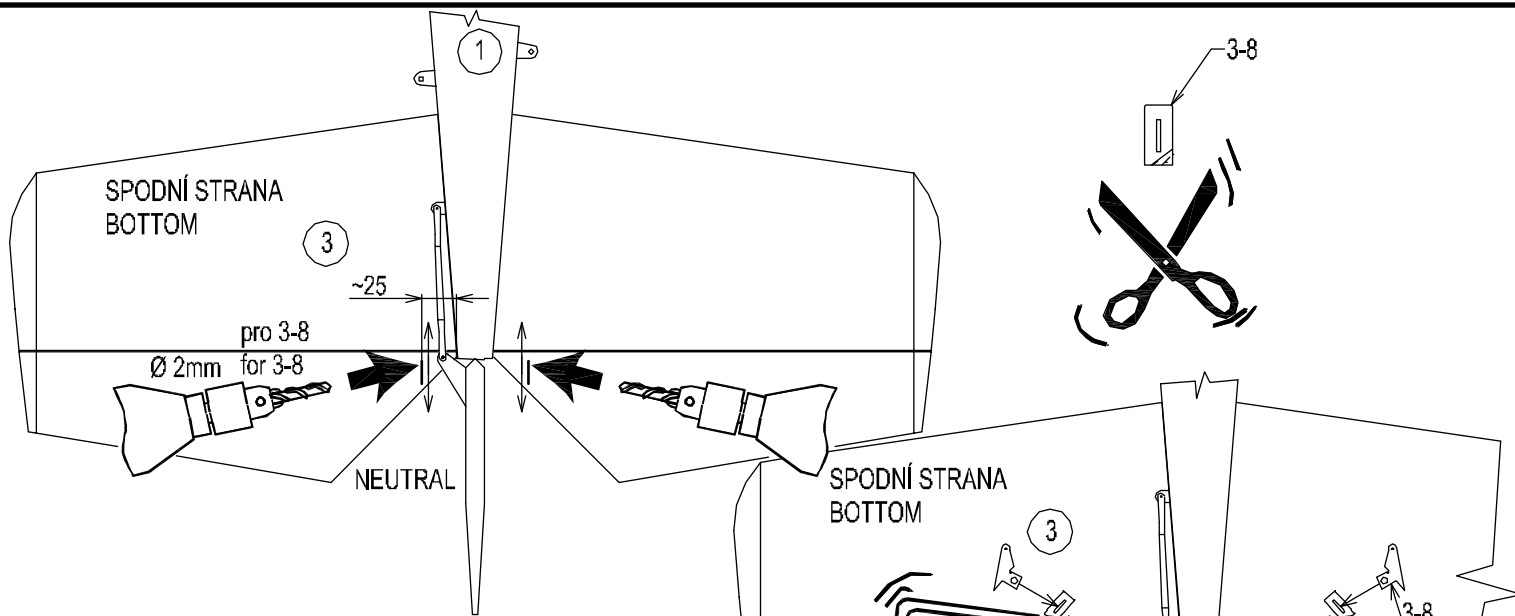

NEUTRAL

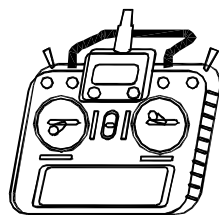
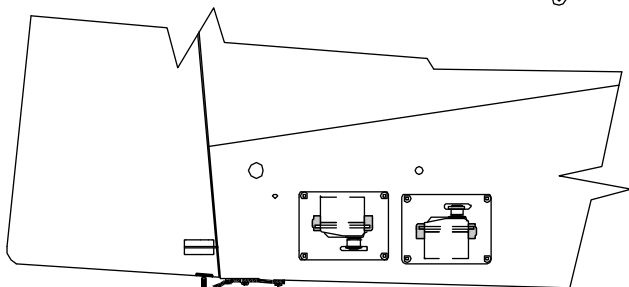
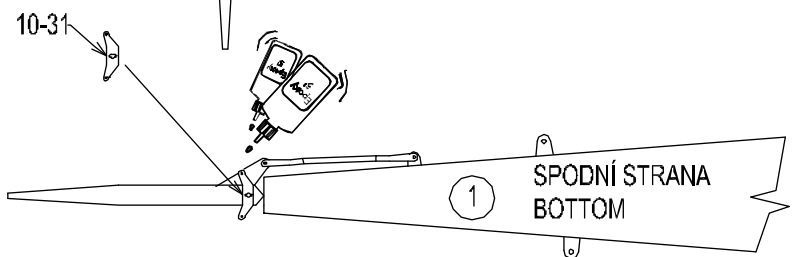
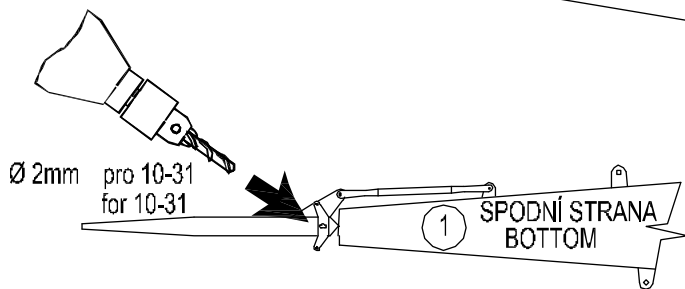
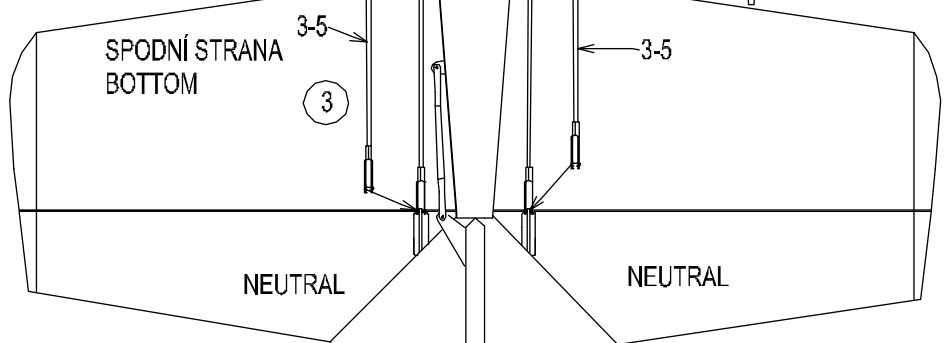

NEUTRAL

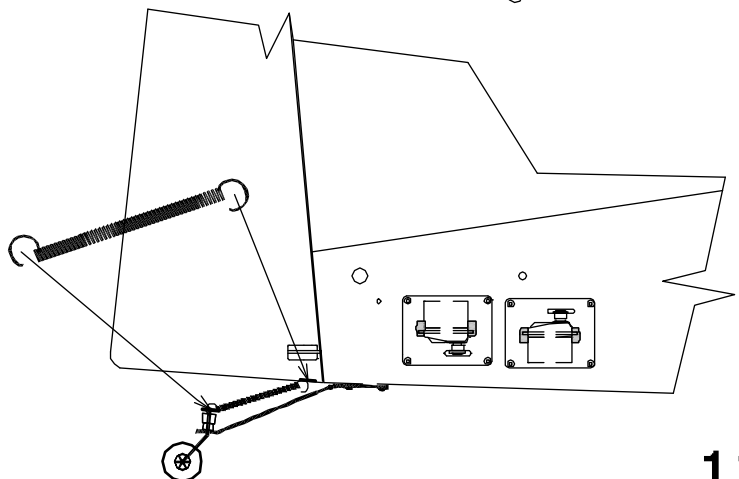

pro 1-51
for 1-51

pro 1-51
for 1-51

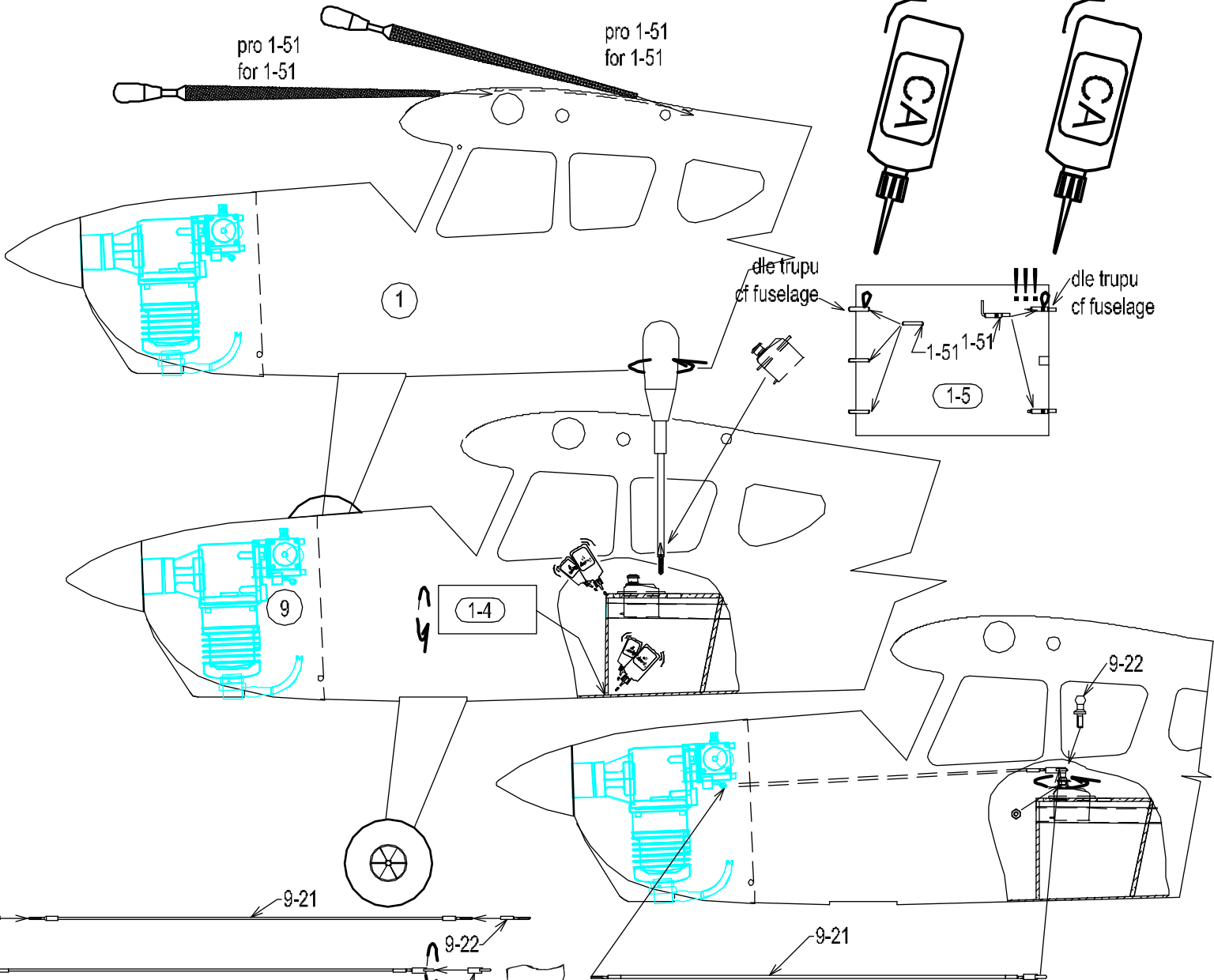
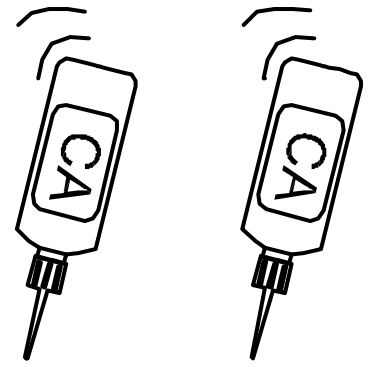

9-22

9-22

9-22

Ø 2,2mm pro 6-1
for 6-1

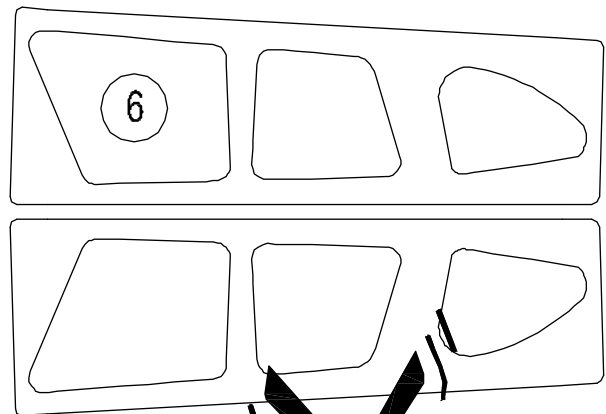
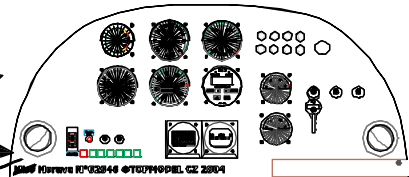

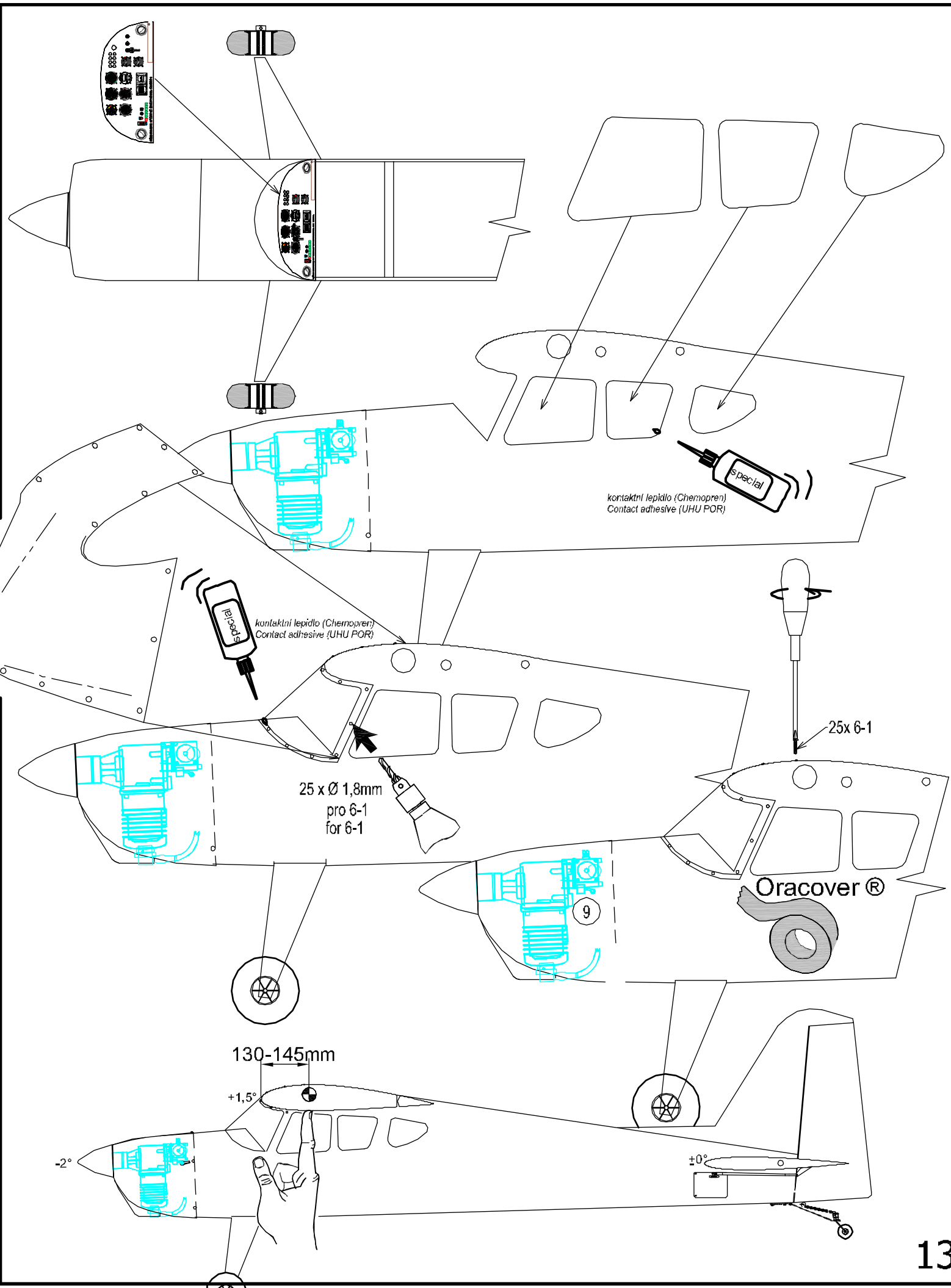

kontaktni lepidlo (Chemopren)
Contact adhesive (UHU POR)

kontaktni lepidlo (Chemopren)
Contact adhesive (UHU POR)

25 x Ø 1,8mm
pro 6-1
for 6-1

25x 6-1

Oracover®

130-145mm

+1,5°

-2°

±0°

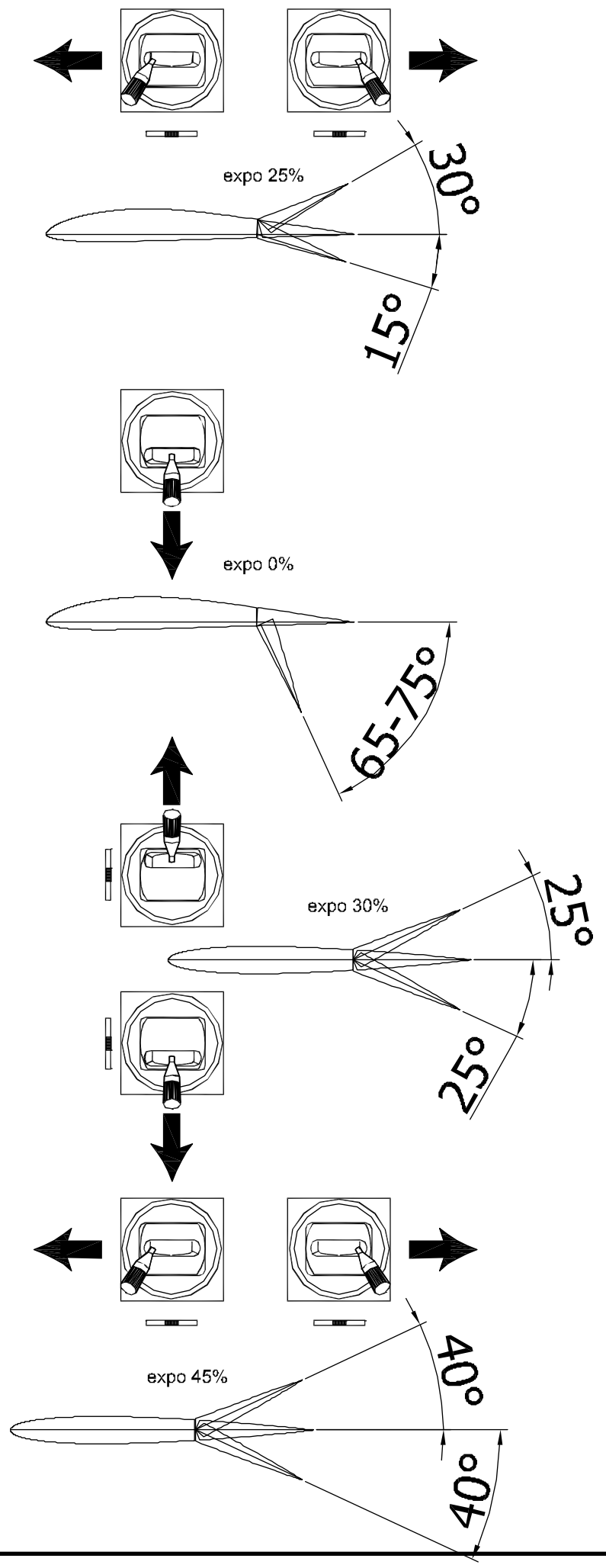
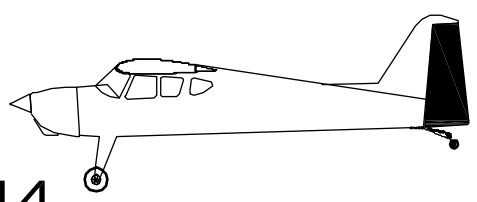
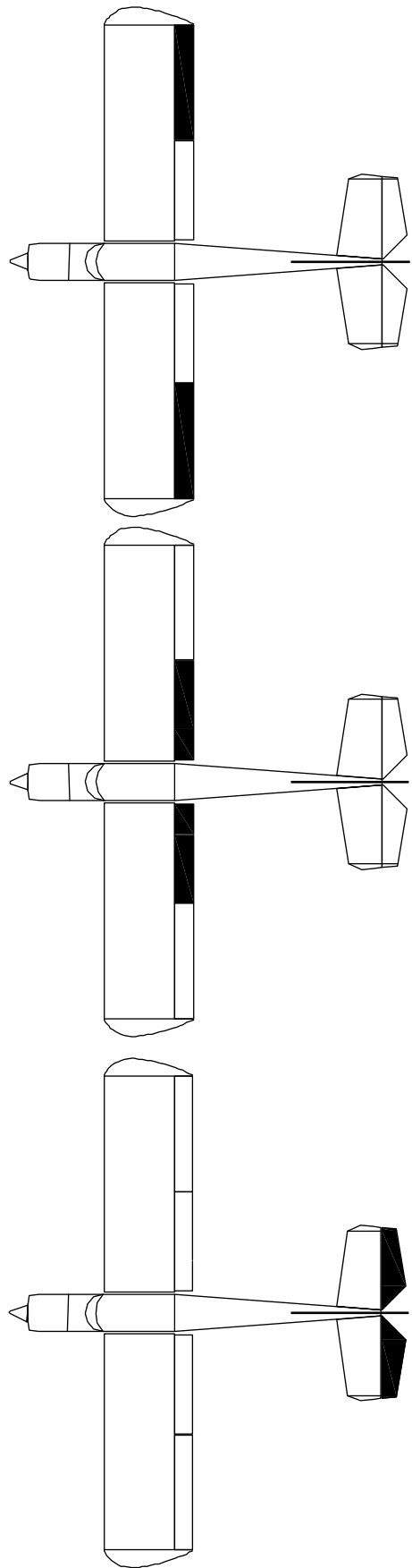

RECOMMENDED EQUIPMENT:

		Pieces		Item No www.topmodelcz.com
Transmitter	7 channel			
Receiver	10 channel			
Servo	HS - 5625MG digi	4	for ailerons & elevator	1HI3200
	HS - 5645MG digi	4	for flaps & rudder& tow hook	1HI3210
	HS-422	2	for engine + 1 for choke	1HI3075
Engine	MVVS 50 IRS ICU-L	1		3005L
Muffler	Compact exhaust for MVVS	1	for MVVS engine	3208I
Spinner:	Fiberglass spinners Ø80mm	1		020CT80A
Propeller	23x8"	1		020G23x8CW
Wheels	Pneumatic wheels Ø100 mm	1 pair		KAV0259
Wheel cover	Wheel covers Tractor	1 pair		02095-8
Fuel tank	Fuel Tank Petrol 500 ml	1		FM-17
Fuel tube	Tygon Fuel Tubing for Petrol 3/6 mm	1		7BA2055
Servo cable	Twisted cable - Large	5,1m		8GR3009
Connector	Connector MPX 6 plug	2		1M60500
Connector	Connector MPX 6 socket	2		1M60501
	MPX 6 connector holder	2		Nes001
Shrink tube	Thermo-Shrinkable insulation	0,7m		9001
Tow hook	Remote tow hook (plane)	1		066RTH

DOPORUČENÉ PŘÍSLUŠENSTVÍ :

		kusů		objednací číslo www.topmodelcz.cz
Vysílač	7 kanál			
Přijímač	10 kanál			
Servo	HS - 5625MG digi	4	pro křídélka a výškovku	1HI3200
	HS - 5645MG digi	4	pro vztlakové klapky a směrovku a vlečný háček	1HI3210
	HS-422 ECO	2	motor a sytič	1HI3075
Motor	MVVS 50 IRS ICU-L	1		3005L
Výfuk	Kompaktní tlumič pro MVVS	1	pro motor MVVS	3208I
Kužel	Laminátový kužel Ø80mm	1		020CT80A
Vrtule	23 x 8"	1		020G23x8CW
Kola	Pneumatická kola Ø100 mm			KAV0259
Nádrž	Nádrž 500 ccm benzin	1		FM-17
Palivová hadička	Had.benzin žlutá Tygon 3/6	1		7BA2055
Kryty kol	Kryty kol Tractor	2	pro kolo φ100mm	02095-8
Konektor	MPX 6 zástrčka	2		1M60500
Konektor	MPX 6 zásuvka	2		1M60501
	Držák konektoru MPX 6	2		Nes001
Kabel serva	Kabel kroucený tlustý	5,1m		8GR3009
Bužírka	Teplem smrštitelná bužírka	0,7m		9001
Vlečný háček	Vypínací háček do vlečné	1		066RTH